

SPECTRA – i.Net®

PRODUCT SHEET & SPECIFICATIONS

MUSIC PAGE INTERFACE (MPI) (MODEL G505)



FUNCTION

Lencore's Music Page Interface (MPI) replaces all the bulky head-end equipment that is associated with music and paging systems. With the MPI there is no need for additional cable home-runs, amplifiers, separate equalizers, special switching equipment or matching vendors for compatible product interfaces. The MPI's technology is so sophisticated that it can allow zone additions, modifications, deletions and other changes to the paging system on the fly, without rewiring. This eliminates the need for running multiple home runs back to the electrical closet or through building risers to create separate or additional zones.

The MPI allows the ability to use up to 99 individual zones for paging using standard DTMF tones through a POTS telephone line. The system is also programmed for all-call and emergency broadcast paging. The system's easy to use full one octave band equalizer can be adjusted to either individual zones or all zones and provides exceptional fine tuning capabilities.

When the MPI is connected to the Spectra i.Net's® web appliance (i.LON®), programming can be set for up to 1.5 million square feet of space through a single device.

The Spectra i.Net® MPI incorporates Point Z™ technology allowing each individual speaker channel to carry up to 10 programmable

zones. Paging has never been so versatile & clean.

The creation, modification, addition and deletion of zones or groups for paging and masking can be easily controlled through the i.LON's® web browser using the included Lencore Sound Manager. No proprietary software needs to be installed on the client's side, eliminating security and migration issues. The Lencore Spectra i.Net® System is an open platform system. In addition, volume and equalizer settings for paging and music can be programmed through the Sound Manager or Spectra i.Net® Reports offering tremendous adjustment and control capabilities with unprecedented flexibility.

Adaptive Equalization: The unmatched capabilities and superior paging quality of Lencore's system automatically compensates and readjusts for frequency line loss while ensuring a quality signal that is continuously and uniformly broadcast and distributed throughout the entire system. Essentially this means that throughout the miles of audio wire, line loss will be virtually negligible. This results in a crystal clear page whenever you need it, wherever you are in your facility.

The MPI unit typically installs in the Telephone or IT closet. The MPI accepts a POTS line for all-call and zoned telephone paging. In addition, there are left and right audio inputs for music, all-call page, microphone input and testing input.

MUSIC PAGE INTERFACE (MPI)

– PAGING VOLUME ADJUSTMENTS

Individual channels

Maximum output – 5.3 Volt RMS at speaker terminal

Attenuation range – 48 dB, in 1 dB steps, plus a mute setting

– PAGING ZONES

Individual channel, groups or global paging zones

Point Z™ Technology (Each channel can carry 10 programmable zones)

– PAGE TESTING SETTINGS

Service Button 1 - starts All Call page and set to on or off

Used for sending continuous audio over inputs for testing

Service Button 2 - sends test audio files over page lines

– LED GUIDES FOR VOLTAGE INPUTS

On back of MPI unit there are two potentiometer to adjust audio and voltage inputs for both paging and music. The LED displays on the front of the unit provides visual confirmation that voltage are in range.

+ LED's 1 (Page) - No Light: No input

Yellow light: Tel/Audio input too low

Blue Light: Good

Red Light: Hot

+ LED's 2 (Music) - No Light: No input

Yellow light: Tel/Audio input too low

Blue Light: Good

Red Light: Hot

– E.B./MUSIC VOLUME ADJUSTMENTS

Independent channels

Maximum output – 5.3 Volt RMS at speaker terminal

Attenuation range – 48 dB, in 1 dB steps, plus a mute setting

– EMERGENCY BROADCAST/MUSIC ZONES

Individual channel, groups or global music zones

– PAGING/E.B./MUSIC OCTAVE EQUALIZER

One page/music equalizer for all channels

10 bands, 31 Hz to 16 kHz, each user adjustable by ±5 dB in 1 dB steps

– POWER SUPPLY

Input from building power – 100-240 VAC, 50-60 Hz, 1.0A

Output to MPI device – 7.5 VDC, 4.0A, 30W max

– DIMENSIONS

6" x 8 3/8" x 1 7/8"

– ELECTRICAL SPECIFICATIONS

Input voltage – 7.5 Volts DC

Input current – 333 milliamps DC

Power usage – 2.5 Watts

Power jack – Mates with 2.1 mm inner

5.5 mm outer

11 mm plug length

On/Off slide switch

– TELEPHONE PAGE USAGE

+ Lift telephone receiver

+ Dial access code – (*) = Backspace

+ Wait for short dial tone

+ Dial two digit paging zone number and the # key or

+ Dial oo# for all call page

+ Wait for short beep

+ Issue page

+ Hang up – (*) = Hang up after zone is dialed

– INPUTS

LonWorks® network. Connects to i.LON®100 Internet Server.

Screw terminals.

+ Audio/Mic input - Microphone input allows stationary mic to be used for MPI input - Dry contact switch allows use to override telephone input

+ Dry Mic Contact Switch - Sends all call page to OP's when closed (overrides tel input). All call off when relay is open

+ Audio/Mic-Tel Switch - Switches between inpus (dry contact overrides switch)

– PAGE

+ POTS line telephone input. RJ11 connector

1. 2 wire (tip and ring) analog appearance

2. Configured to be loop start

3. Battery voltage is 48 volts

4. Loop current is 23 milli amps

5. Must have DTMF signaling capability

6. Must have hang-up (winking) supervision

SPECTRA – i.Net®

MUSIC PAGE INTERFACE (MPI)

– STEREO / MUSIC

- + Left channel, 10k ohm input impedance, unbalanced, single ended RCA jack (phono connector)
- + Right channel, 10k ohm input impedance, unbalanced, single ended RCA jack.
- + Input impedance is 10K ohms
- + Gain from RCA jack to RJ45 pins 7 and 8 is 2 when internal potentiometer is set to maximum. (With 620 ohm terminator)
Note: Left and right channels are combined to form one music input. All music inputs using the RCA jacks are single ended inputs.



– RECOMMENDED SETTING OF INTERNAL POTENTIOMETER OF MUSIC INPUT

- + USA professional audio, +4 dBu, 1.228 Vrms
10 o'clock position (approximate)
- + Consumer audio, -10 dBV, 0.316 Vrms
3 o'clock position (approximate)
- + Tungsten T3 PDA,
5 o'clock position (approximate)
- + Ipod,
3 o'clock position (ipod volume set to 3/4)
- + 1 Vrms signal generator,
10 o'clock position (approximate)
- + 0.7746 signal generator,
11 o'clock position (approximate)

Ex: Set POT to min if input is 1 Vrms
Set POT to max if input is .25 Vrms
*Do NOT exceed 1 Vrms input

– OUPUTS

- + Cat5e data cable, RJ45 connector. Connects to OP's
- + Page output, pins 4 and 5 of RJ45 is a balanced output
- + Music output, pins 7 and 8 of RJ45 is a balanced output
- + Two ground (common) screw terminal block. Connects to (-), ground, of first OP

– ADAPTIVE EQ OUTPUTS

Besides the normal Adaptive EQ procedure these output signals can be used as a signal generator. All measurements are made differentially with a ground strap from MPI board to test equipment. Short Cat5e were used, approximately 6-feet.

31 Hz. – 0.440 Vrms (1.2445 Vp-p) unterminated
0.297 Vrms (0.8400 Vp-p) terminated into 620 ohms

63 Hz. – 0.495 Vrms (1.4001 Vp-p) unterminated
0.410 Vrms (1.1597 Vp-p) terminated into 620 ohms

125 Hz. – 0.514 Vrms (1.4538 Vp-p) unterminated
0.460 Vrms (1.3011 Vp-p) terminated into 620 ohms

250 Hz. – 0.518 Vrms (1.4651 Vp-p) unterminated
0.475 Vrms (1.3435 Vp-p) terminated into 620 ohms

500 Hz. – 0.516 Vrms (1.4595 Vp-p) unterminated
(500 Hz is best for field testing)
0.476 Vrms (1.3463 Vp-p) terminated into 620 ohms

1 kHz. – 0.500 Vrms (1.4142 Vp-p) unterminated
0.463 Vrms (1.3096 Vp-p) terminated into 620 ohms

2 kHz. – 0.450 Vrms (1.2728 Vp-p) unterminated
0.417 Vrms (1.1795 Vp-p) terminated into 620 ohms

4 kHz. – 0.348 Vrms (0.9843 Vp-p) unterminated
0.322 Vrms (0.9108 Vp-p) terminated into 620 ohms

8 kHz. – 0.241 Vrms (0.6817 Vp-p) unterminated
0.223 Vrms (0.6307 Vp-p) terminated into 620 ohms

16 kHz. – 0.186 Vrms (0.5261 Vp-p) unterminated
0.172 Vrms (0.4865 Vp-p) terminated into 620 ohms

MUSIC PAGE INTERFACE (MPI)

– MPI FEATURES & BENEFITS

- + Local paging via telephone - up to 100 zones
- + Global input for multi-building, campus wide paging
- + Mic or canned announcement input to override for emergency notification
- + Service buttons #1 and #2 allows for full test for page continuity over entire system
- + Music input to easily play music over system or zone
- + AGC (Automatic Gain Control) implemented to ensure quality paging

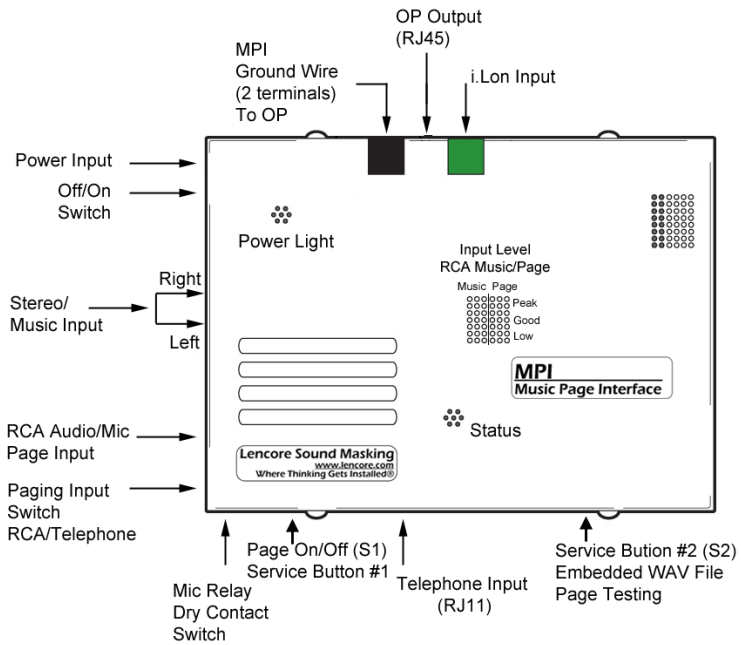

- + Variable input control for music and RCA Audio/ Mic Paging input with LED metering for proper input voltage
- + LED display on front displays input levels as low, hot or good
- + Variable input controls and metering capabilities ensures clean input and quality connections

